

Cleco

MOUNTABLE POWER MOTORS



Cleco | Tame the Line

SHOWN: MA3 SERIES - AIR MOTOR

MOUNTABLE POWER MOTORS

**Choose the right
Air Motor to fit your
application.**

Apex Tool Group's air motors are engineered for flexibility and reliability. Cleco air motors cover a wide range of uses where compressed air is advantageous: powering air driven machinery, raising foundry copes and drags, rotating a turntable, mixing paint, powering cranes, valve actuation, or power source for mechanical hands or universal joints.

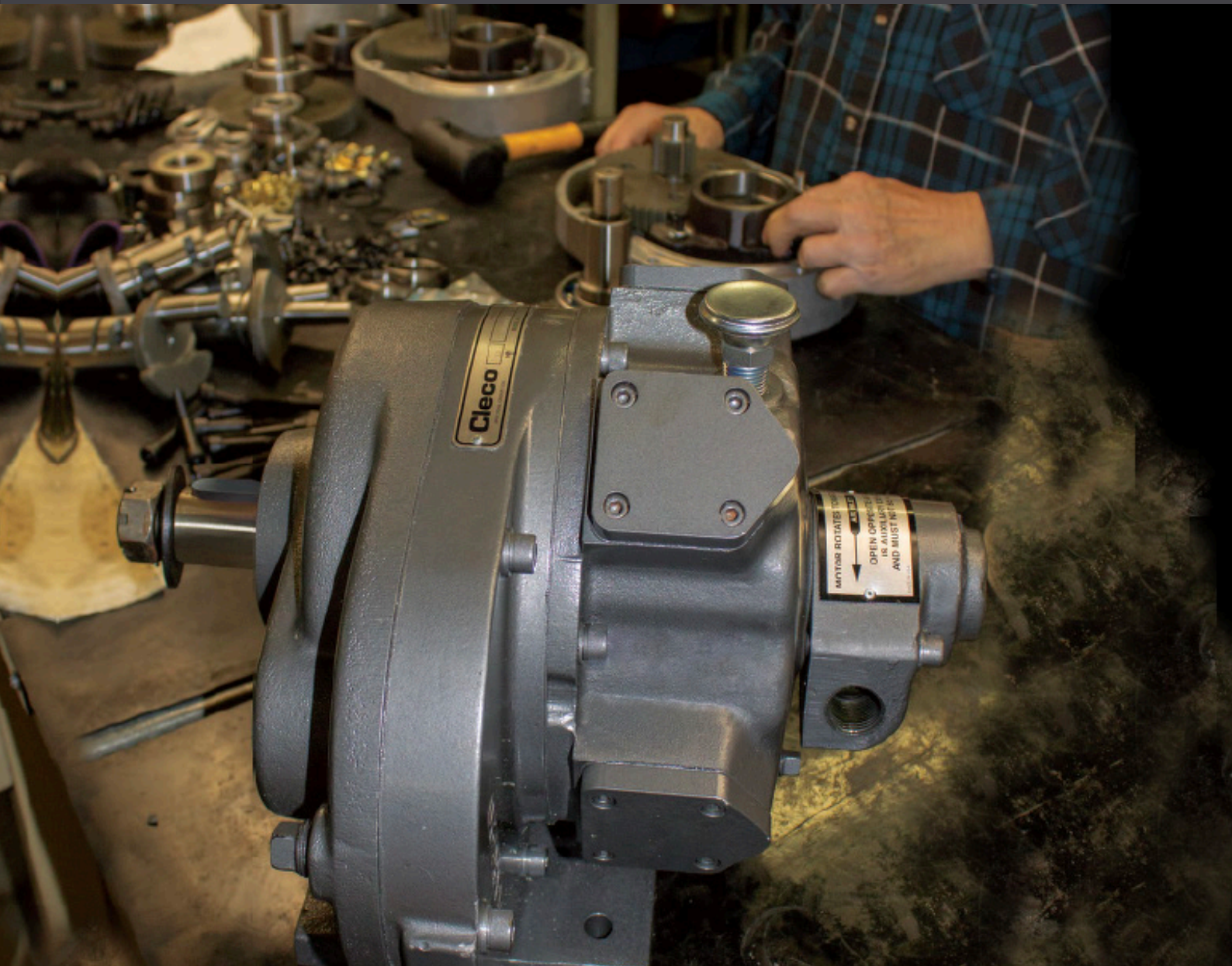

22 Series - Air Motor - Rotary Vane - Reversible/Non Reversible



Maximum Power 0.7 hp | 0.52 kw

- Maximum Power 0.7 hp | 0.52 kw
- Torque Range 0.6 - 28.4 ft. lbs. | 0.81 - 38.48 Nm

Model	Mount	Spindle Type	RPM at Max HP	Free Speed	Torque Stall	Weight		Gear Ratio	Length	Horsepower	Air Consumption	Control
			r/min	r/min	Ft Lb Nm	Lb	kg		in mm	Hp kW	Scfm	
22M5070-50	Flange and Base Mounting	1/2 in Keyed Spindle	165	330	28.4 38.48	3.06	1.39	50.4-1	7.88 200	0.7	29	Reversible
22M5070-60	Flange and Base Mounting	1/2-20 Threaded Spindle	165	330	28.4 38.48	3.06	1.39	50.4-1	7.88 200	0.7	29	Reversible
22V5040-50	Flange and Base Mounting	1/2" in Keyed Spindle	215	430	5.8 7.86	4.0	1.81	38.7-1	7.88 200	0.9	29	LH Rotation
22M5071-50	Flange and Base Mounting	1/2" in Keyed Spindle	250	500	19.6 26.56	3.06	1.39	34.8-1	7.88 200	0.7	29	Reversible
22M5270-50	Flange and Base Mounting	1/2" in Keyed Spindle	1200	2400	4.0 5.42	2.38	1.08	7.1-1	6.16 156	0.7	29	Reversible
22M5340-50	Flange and Base Mounting	1/2" in Keyed Spindle	1600	3200	5.8 7.86	4.0	1.81	7.1-1	6.19 157	0.9	29	Non-Reversible
22M5440-50	Flange and Base Mounting	1/2" in Keyed Spindle	2350	4700	4.0 5.42	4.0	1.81	4.9-1	6.19 157	0.9	29	Non-Reversible

Air Inlet: 1/4" NPT-Side and rear
 Air consumption: 29 cfm(.82 m3/min)
 All tools performance rated @ 90psi(620 kPa) air pressure
 Standard Equipment:
 Hex socket screw provided for closure of unused inlet
 Flush fitting for lubrication of gears

22M Series Motor Dimensions

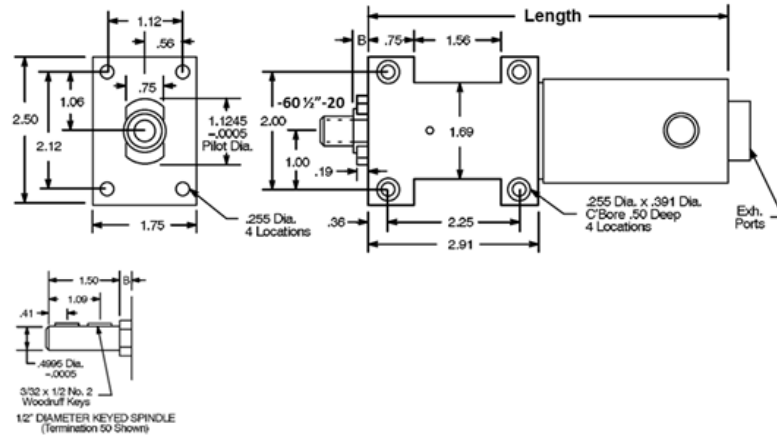

22M Speed Torque Data Non-Reversible

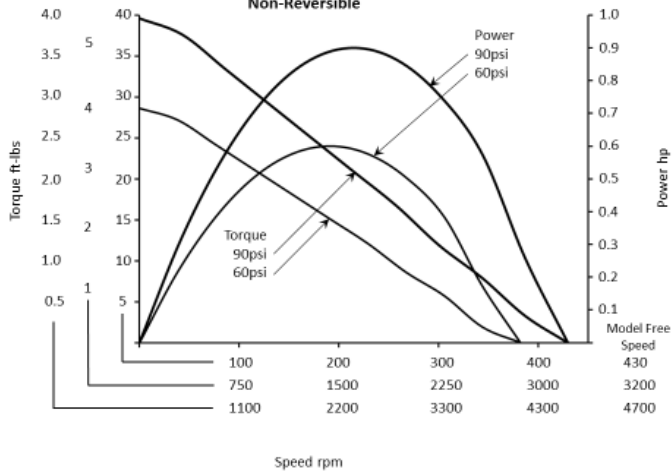

22M Speed Torque Data Reversible

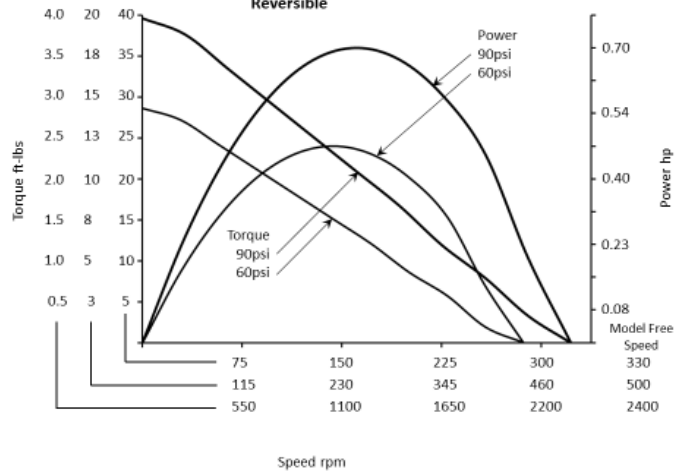

A2 Series - Air Motor - Axial Piston

Maximum Power 0.6 hp | 0.45 kw

- Maximum Power 0.6 hp | 0.45 kw
- Torque Range 2 - 107 ft. lbs. | 2.7 - 145 Nm
- Reversible
- Rear Exhaust
- Keyed Spindle



Model	Mount	Spindle Type	RPM at Max HP	Free Speed	Torque Stall	Weight		Gear Ratio	Length	Horsepower	Air Consumption	Control
			r/min	r/min	Ft Lb Nm	Lb	kg		in mm	Hp kW	Scfm	
A2R306M	Face Mounting	7/8 in Keyed Spindle	44	90	107 145	22	10	53.6-1	14.28 363	0.6	21.2	Reversible
A2R305M	Face Mounting	7/8 in Keyed Spindle	75	150	63.0 85	22	10	31.4-1	14.28 363	0.6	21.2	Reversible
A2R304M	Face Mounting	7/8 in Keyed Spindle	99	200	48.0 65	22	10	23.8-1	14.28 363	0.6	21.2	Reversible
A2R303M	Face Mounting	7/8 in Keyed Spindle	169	345	28.0 38	22	10	13.9-1	14.28 363	0.6	21.2	Reversible
A2R302M	Face Mounting	7/8 in Keyed Spindle	255	520	19.0 26	14	6.35	9.25-1	12.12 308	0.6	21.2	Reversible
A2R301M	Face Mounting	7/8 in Keyed Spindle	575	1170	8.0 11	14	6.35	4.1-1	12.12 308	0.6	21.2	Reversible

All models assume overhung load located at 1.75" (44.45mm) from face of motor.

These motors must be operated with sufficient load to prevent speed from exceeding maximum allowable speed, 75% of free speed as shown on performance curve.

General:

Air Inlet: 3/8" NPTF

All tools performance rated @ 90psi (620 kPa) air pressure.

Optional Equipment:

Lubricating Oil - Part 533485 (1 gallon) Airube 10W/NR

Gear Grease - Part A123771 (16oz) Shell Gadus S2 V220 00

22M Series Motor Dimensions

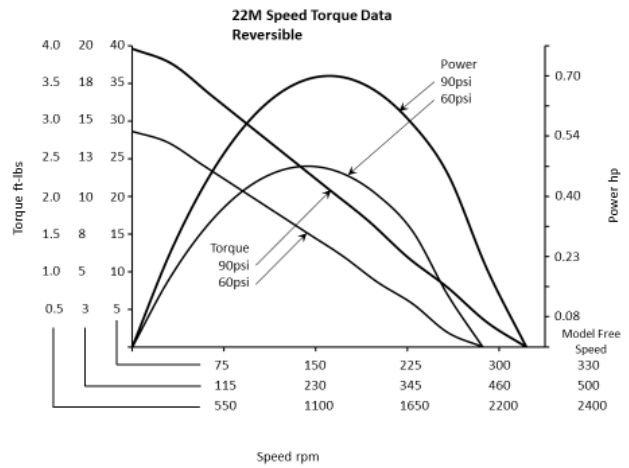
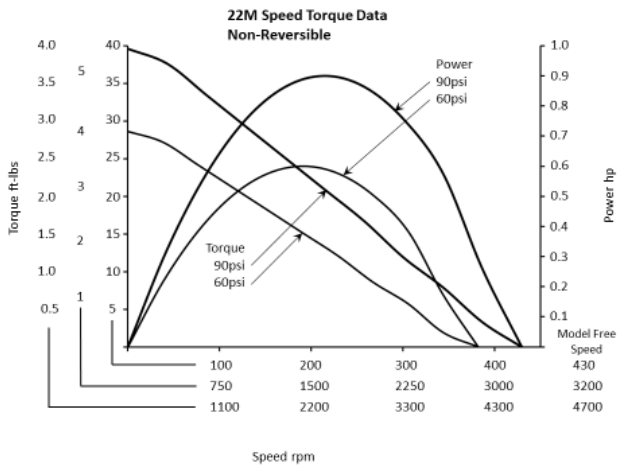
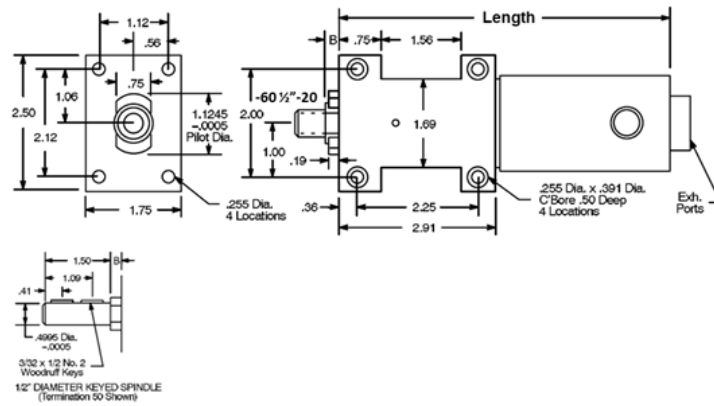

B4 Series - Air Motor - Axial Piston

Maximum Power 0.9 hp | 0.67 kw

- Maximum Power 0.9 hp | 0.67 kw
- Torque Range 4 - 232 ft. lbs. | 6.8 - 315 Nm
- Reversible
- Rear Exhaust
- Keyed Spindle



Model	Mount	Spindle Type	RPM at Max HP	Free Speed	Torque Stall	Weight		Gear Ratio	Length	Horsepower	Air Consumption	Control
			r/min	r/min	Ft Lb Nm	Lb	kg		in mm	Hp kW	Scfm	
B4R317M	Face Mounting	7/8 in Keyed Spindle	46	90	232.0 315	22.5	10.2	46.4-1	15.21 386	0.9	39.9	Reversible
B4R322M	Face Mounting	7/8 in Keyed Spindle	79	150	136.0 184	22.5	10.2	27.2-1	15.21 386	0.9	39.9	Reversible
B4R323M	Face Mounting	Discontinued	90	175	119.0 161	22.5	10.2	23.8-1	15.21 386	0.9	39.9	Reversible
B4R320M	Face Mounting	7/8 in Keyed Spindle	154	300	70.0 95	22.5	10.2	13.9-1	15.21 386	0.9	39.9	Reversible
B4R318M	Face Mounting	7/8 in Keyed Spindle	270	525	40.0 54	14.5	6.6	8-1	13.19 335	0.9	39.9	Reversible
B4R319M	Face Mounting	7/8 in Keyed Spindle	525	1020	21.0 28	14.5	6.6	4.1-1	13.19 335	0.9	39.9	Reversible
B4R321M	Face Mounting	Discontinued	2150	4200	5.0 6.8	14.5	6.6	1-1	13.19 335	0.9	39.9	Reversible

All models assume overhung load located at 1.75" (44.45mm) from face of motor.
 These motors must be operated with sufficient load to prevent speed from exceeding maximum allowable speed, 75% of free speed as shown on performance curve.

General:

Air Inlet: 3/8" NPTF

All tools performance rated @ 90psi (620 kPa) air pressure.

Optional Equipment:

Exhaust Muffler - Part 813485

Lubricating Oil - Part 533485 (1 gallon) Airlube 10W/NR

Gear Grease - Part A123771 (16oz) Shell Gadus S2 V220 00

B4 Series Motor Dimensions

Gear Ratio

- 1-1
- 4.1-1
- 8-1

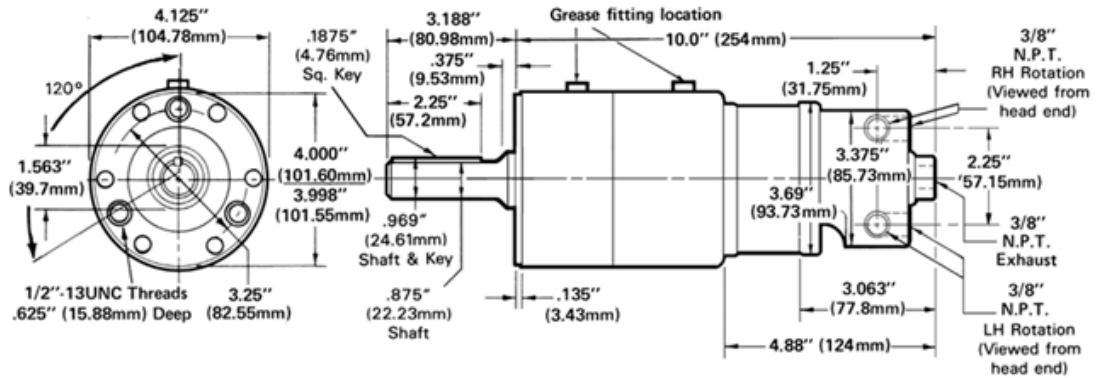

- 13.9-1
- 23.8-1
- 27.2-1
- 46.4-1

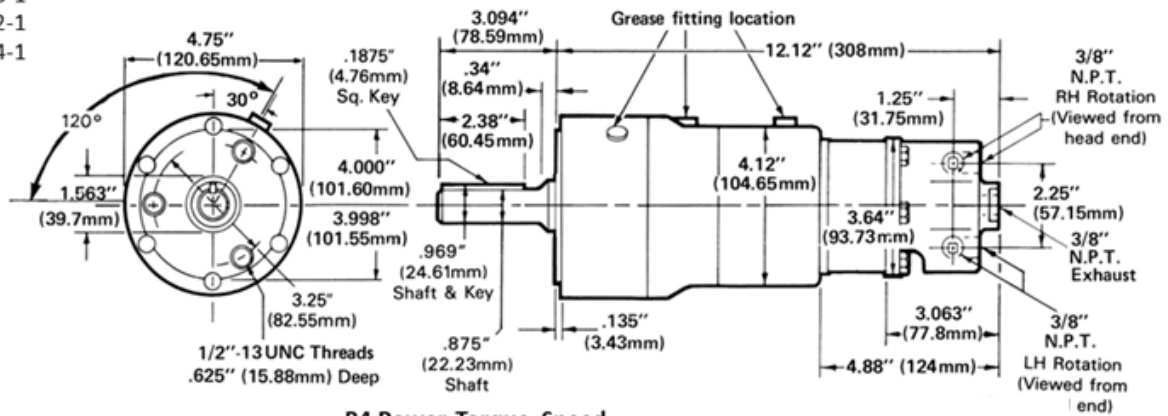

B4 Power, Torque, Speed

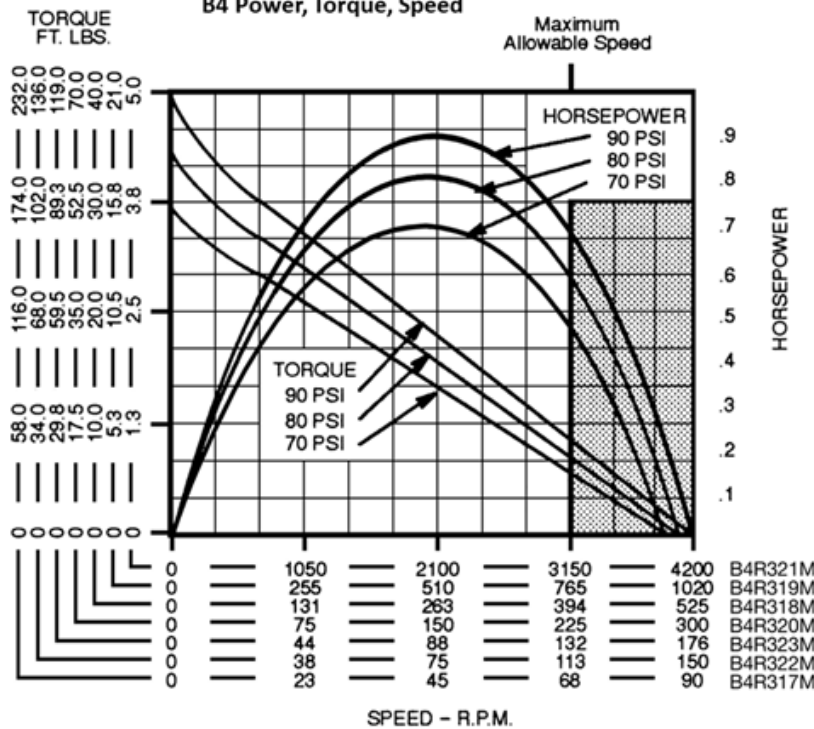

A6 Series - Air Motor - Axial Piston

Maximum Power 1.9 hp | 1.42 kw

- Maximum Power 1.9 hp | 1.42 kw
- Torque Range 11 - 370 ft. lbs. | 15 - 502 Nm
- Reversible
- Rear Exhaust
- Keyed Spindle

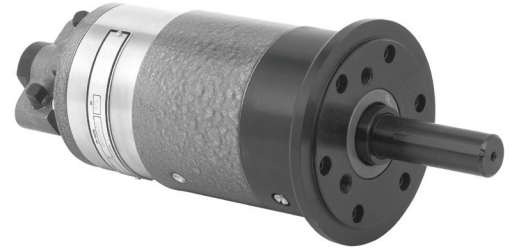

Model	Mount	Spindle Type	RPM at Max HP	Free Speed	Torque Stall	Weight		Gear Ratio	Length	Horsepower	Air Consumption	Control
			r/min	r/min	Ft Lb Nm	Lb	kg		in mm	Hp kW	Scfm	
A6R331M	Face Mounting	1 1/8 in Keyed Spindle	54	100	370.0 502	43	19.5	33.6-1	19.06 484	1.9	62	Reversible
A6R333M	Face Mounting	1 1/8 in Keyed Spindle	89	170	223.0 302	43	19.5	20.3-1	19.06 484	1.9	62	Reversible
A6R332M	Face Mounting	1 1/8 in Keyed Spindle	152	290	130.0 176	43	19.5	11.9-1	19.06 484	1.9	62	Reversible
A6R307M	Face Mounting	1 1/8 in Keyed Spindle	315	605	64.0 87	27	12.2	5.8-1	15.88 403	1.9	62	Reversible
A6R335M	Face Mounting	1 1/8 in Keyed Spindle	535	1030	37.0 50	27	12.2	3.4-1	15.88 403	1.9	62	Reversible
A6R308M	Face Mounting	Discontinued	1820	3500	1.0 15	27	12.2	1-1	15.88 403	1.9	62	Reversible

All models assume overhung load located at 2.25" (57.15mm) from face of motor. These motors must be operated with sufficient load to prevent speed from exceeding maximum allowable speed, 75% of free speed as shown on performance curve.

General:

Air Inlet: 3/8" NPTF

All tools performance rated @ 90psi (620 kPa) air pressure.

Optional Equipment:

Exhaust Muffler - Part 81348 Lubricating Oil - Part 533485 (1 gallon) AirLube 10W/NR

Gear Grease - Part A123771 (16oz) Shell Gadus S2 V220 0

A6 Series Motor Dimensions

Gear Ratio

- 1-1
- 3.4-1
- 5.8-1

- 11.9-1
- 20.3-1
- 33.6-1

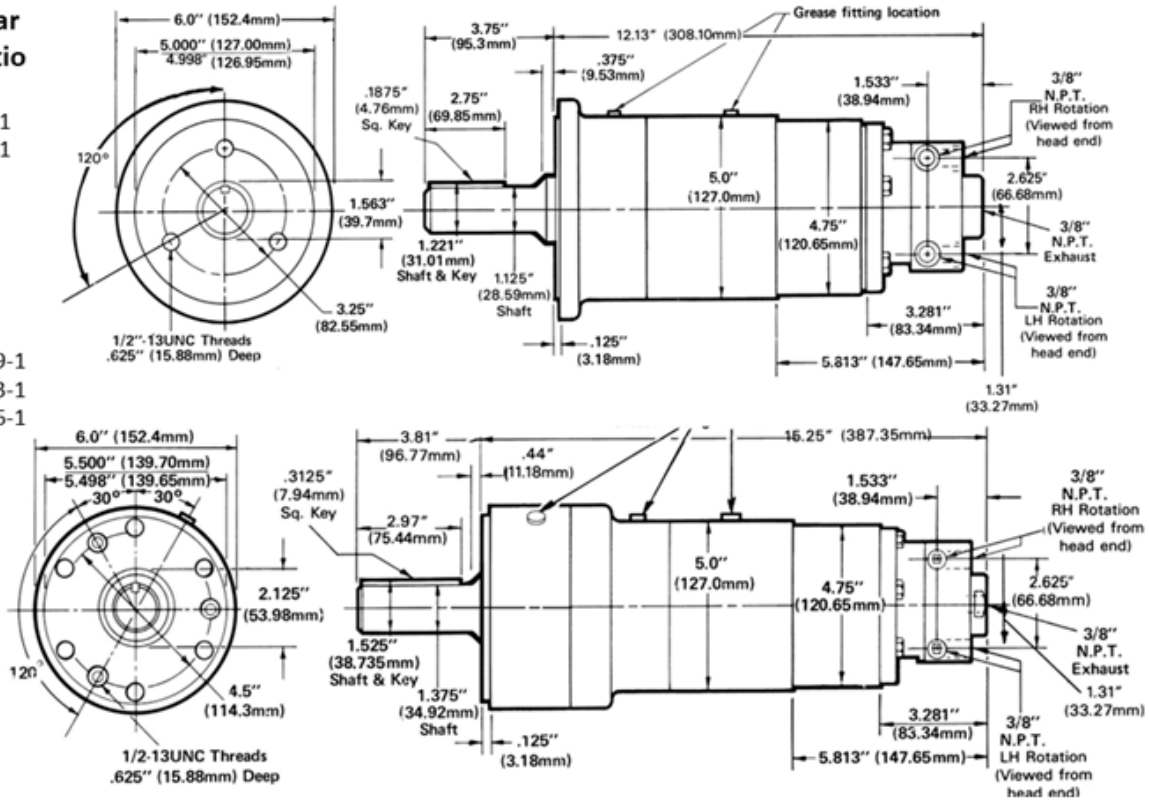

A6 Power, Torque, Speed

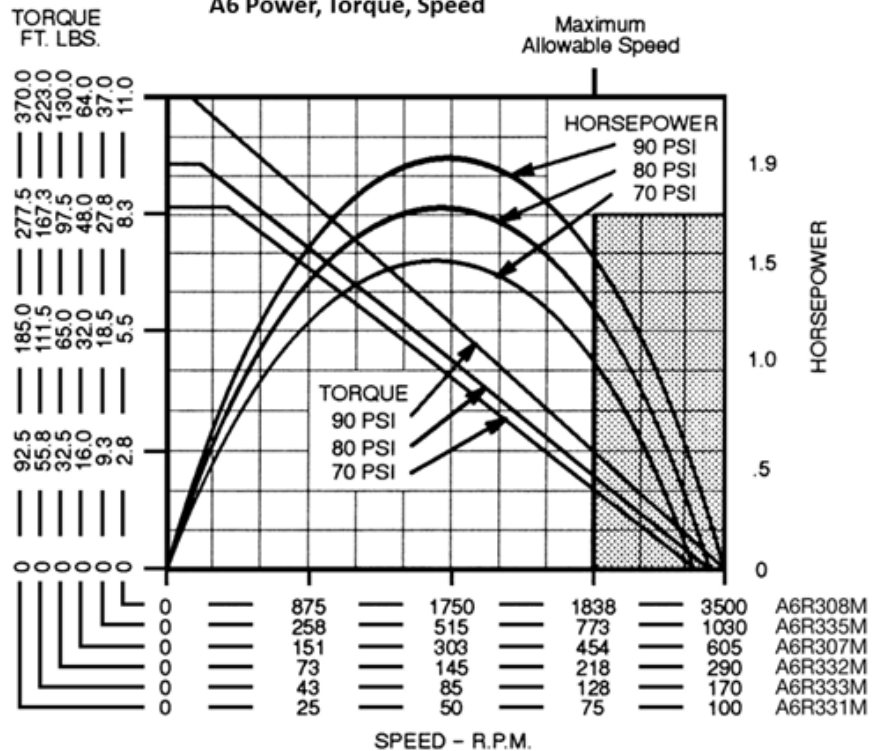

A8 Series - Air Motor - Axial Piston

Maximum Power 2.7 hp | 2.01 kw

- Maximum Power 2.7 hp | 2.01 kw
- Torque Range 19 - 638 ft. lbs. | 26 - 865 Nm
- Reversible
- Rear Exhaust
- Keyed Spindle



Model	Mount	Spindle Type	RPM at Max HP	Free Speed	Torque Stall	Weight		Gear Ratio	Length	Horsepower	Air Consumption	Control
			r/min	r/min	Ft Lb Nm	Lb	kg		in mm	Hp kW	Scfm	
A8R336M	Face Mounting	1 3/8 in Keyed Spindle	38	75	638.0 865	51	23.1	33.6-1	20.63 524	2.7	112	Reversible
A8R338M	Face Mounting	1 3/8 in Keyed Spindle	65	125	385.0 522	51	23.1	20.3-1	20.63 524	2.7	112	Reversible
A8R337M	Face Mounting	1 3/8 in Keyed Spindle	109	215	226.0 306	51	23.1	11.9-1	20.63 524	2.7	112	Reversible
A8R311M	Face Mounting	1 1/8 in Keyed Spindle	225	450	110.0 149	38	17.2	5.8-1	17.5 445	2.7	112	Reversible
A8R310M	Face Mounting	1 1/8 in Keyed Spindle	375	765	64.0 87	38	17.2	3.4-1	17.5 445	2.7	112	Reversible
A8R309M	Face Mounting	1 1/8 in Keyed Spindle	1300	2600	19.0 26	38	17.2	1-1	17.5 445	2.7	112	Reversible

All models assume overhung load located at 2.25" (57.15mm) from face of motor. These motors must be operated with sufficient load to prevent speed from exceeding maximum allowable speed, 75% of free speed as shown on performance curve.

General:

Air Inlet: 1/2" NPTF

All tools performance rated @ 90psi (620 kPa) air pressure.

Optional Equipment

Lubricating Oil - Part 533485 (1 gallon) Airube 10W/NR

Gear Grease - Part A123771 (16oz) Shell Gadus S2 V220 00

A8 Series Motor Dimensions

- Gear Ratio**
 1-1
 3.4-1
 5.8-1

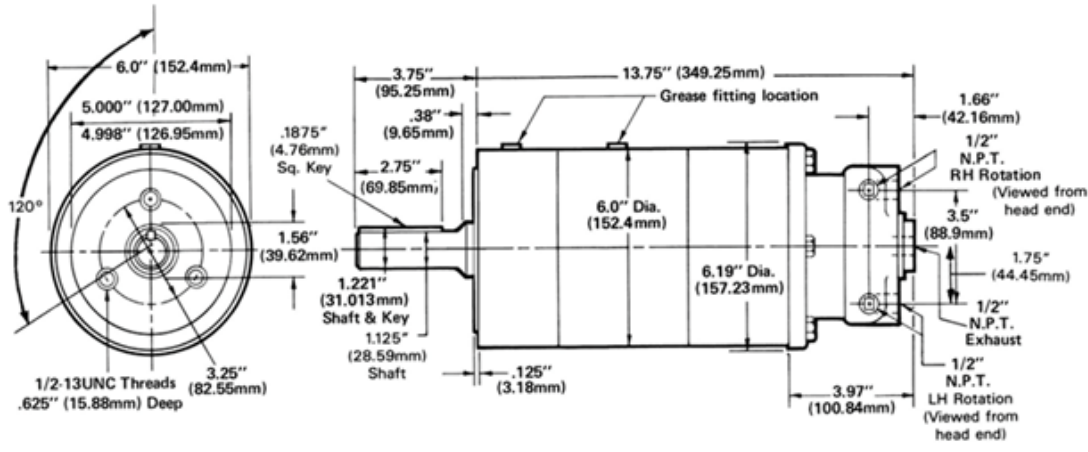

- 11.9-1
 20.3-1
 33.6-1

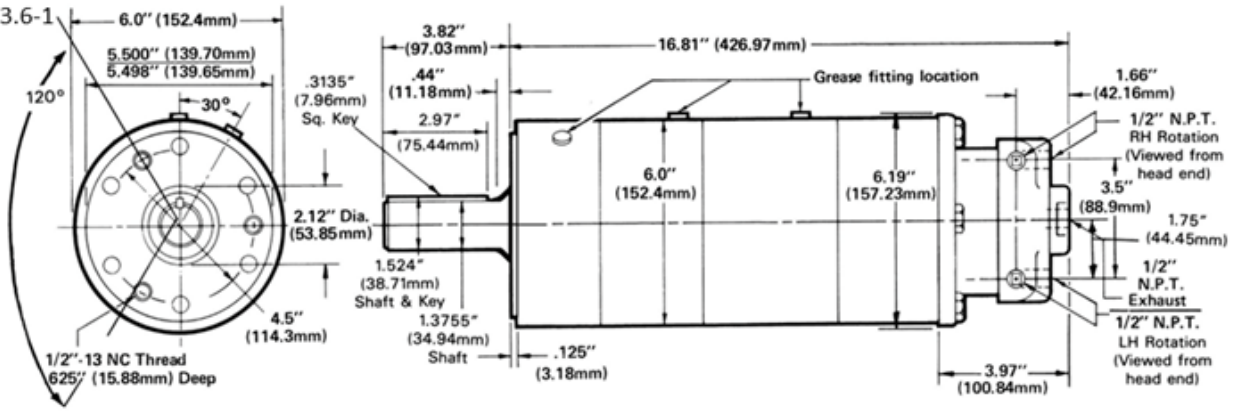

A8 Power, Torque, Speed

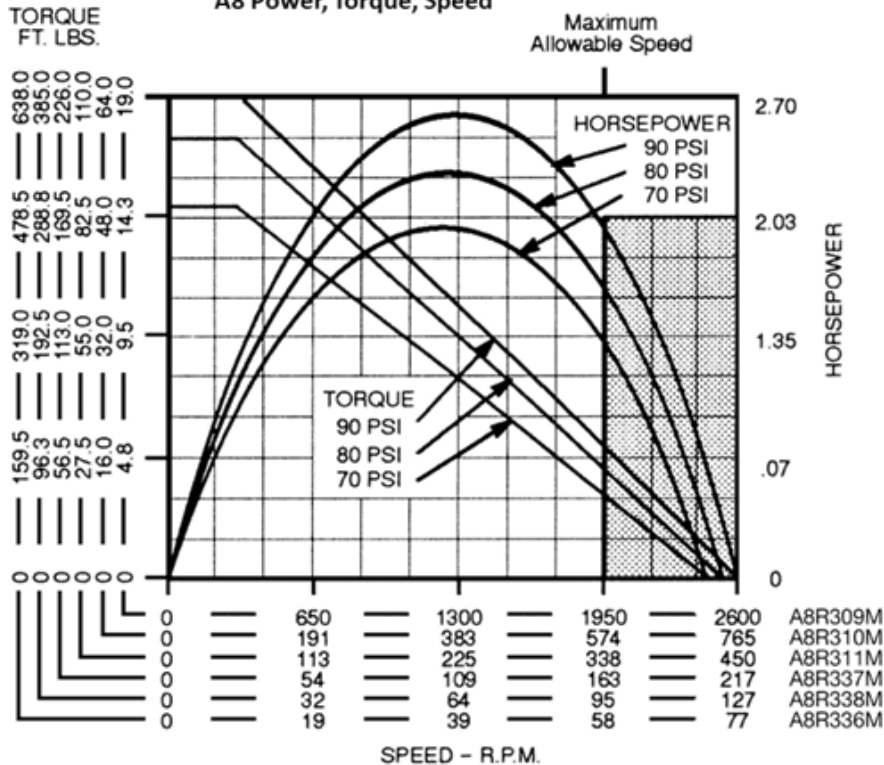

MA2 Series - Air Motor - Radial Piston

Maximum Power 1.5 hp | 1.12 kw

- Maximum Power 1.5 hp | 1.12 kw
- Torque Range 8.6 - 262 ft. lbs. | 12 - 355 Nm
- Threaded Spindle

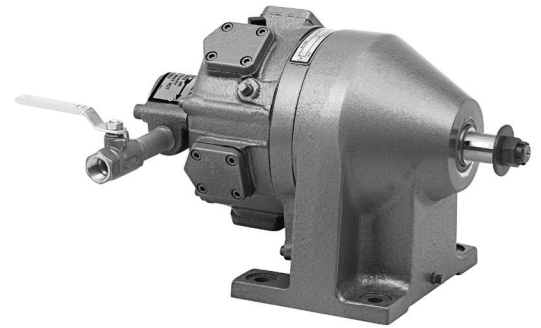

Model	Mount	Spindle Type	RPM at Max HP	Free Speed	Torque Stall	Weight		Gear Ratio	Length	Horsepower	Air Consumption	Control
			r/min	r/min	Ft Lb Nm	Lb	kg		in mm	Hp kW	Scfm	
MA2W403M	Foot Mounting	5/8 in Threaded Spindle	60	120	262.0 355	43	19.5	30.4-1	14.6 371	1.5	58	No Valving

All models assume overhung load located at 0.625" (15.88mm) from face of motor.

These motors must be operated with sufficient load to prevent speed from exceeding maximum allowable speed shown on performance curve.

General:

Air Inlet: 1/2" NPTF

All tools performance rated @ 90psi (620 kPa) air pressure.

Note::

Fill the motor to the proper level before operating. Use engine oil API Service Classified "SC" in the following weights:

Above 32° F: SAE 30W

Below 32° F: SAE 10W

MA2 Series Motor Dimensions

Gear Ratio
30.4:1

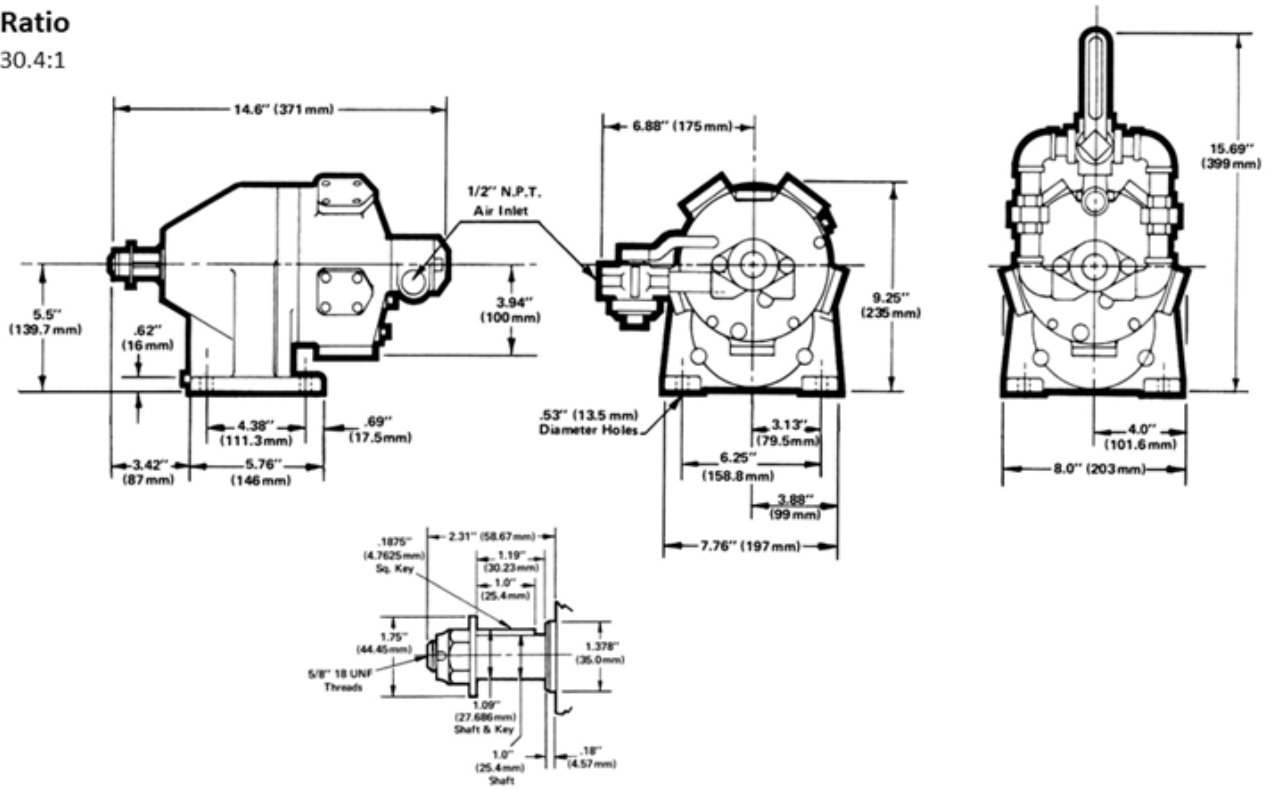

MA2 Power, Torque, Speed

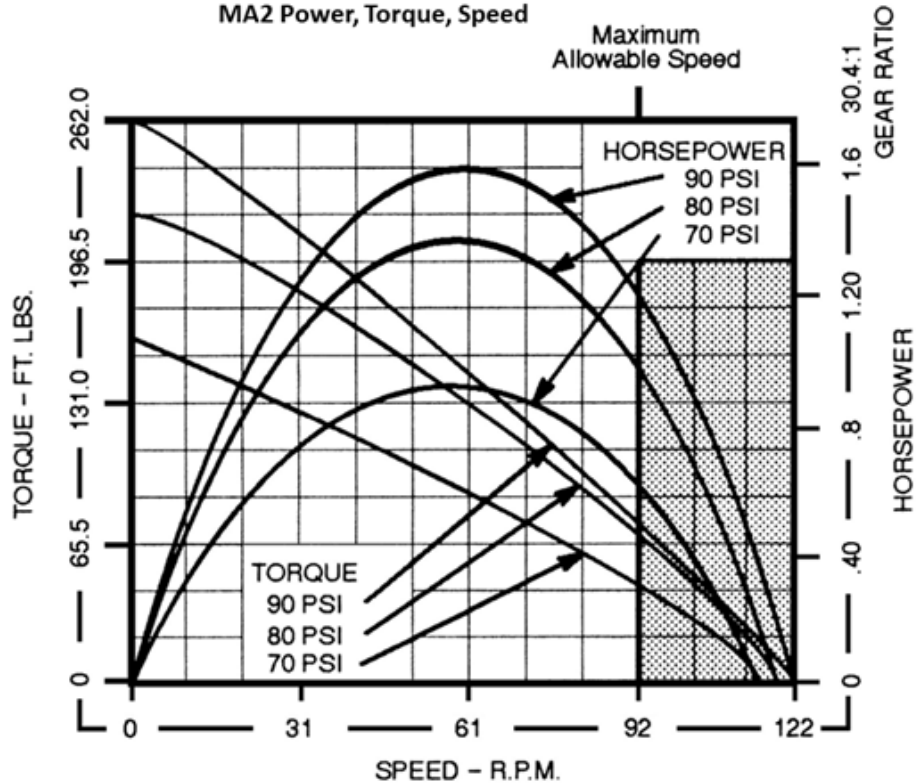

MA3 Series -Air Motor - Radial Piston

Maximum Power 3.0 hp | 2.24 kw

- Maximum Power 3.0 hp | 2.24 kw
- Torque Range 24 - 588 ft. lbs. | 33 - 797 Nm
- Threaded Spindle

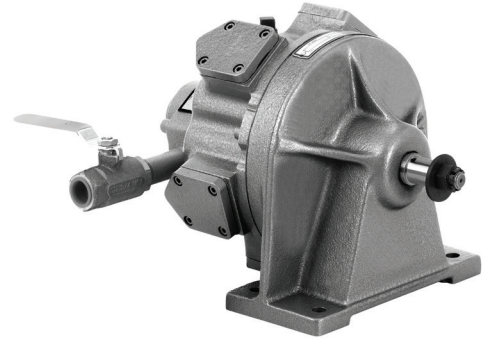

Model	Mount	Spindle Type	RPM at Max HP	Free Speed	Torque Stall	Weight		Gear Ratio	Length	Horsepower	Air Consumption	Control
			r/min	r/min	Ft Lb Nm	Lb	kg		in mm	Hp kW	Scfm	
MA3W407M	Foot Mounting	5/8 in Threaded Spindle	48	100	588.0 797	67	30.1	24.6-1	16.56 421	3.0	95	No Valving
MA3W406M	Foot Mounting	5/8 in Threaded Spindle	1190	2600	24.0 33	51	23.1	1-1	13.76 350	3.0	80	No Valving

Non-geared models assume overhung load located at 0.625" (15.88mm) from face of motor.
 Geared models assume overhung load located at 1" (25.40mm) from face of motor.
 These motors must be operated with sufficient load to prevent speed from exceeding maximum allowable speed, 65% of free speed as shown on performance curve.
 General:
 Air Inlet: 3/4" NPTF
 All tools performance rated @ 90psi (620 kPa) air pressure.
 Note:
 Fill the motor to the proper level before operating. Use engine oil API Service Classified "SC" in the following weights:
 Above 32° F: SAE 30W
 Below 32° F: SAE 10W

Gear Ratio
1:1

MA3 Series Motor Dimensions

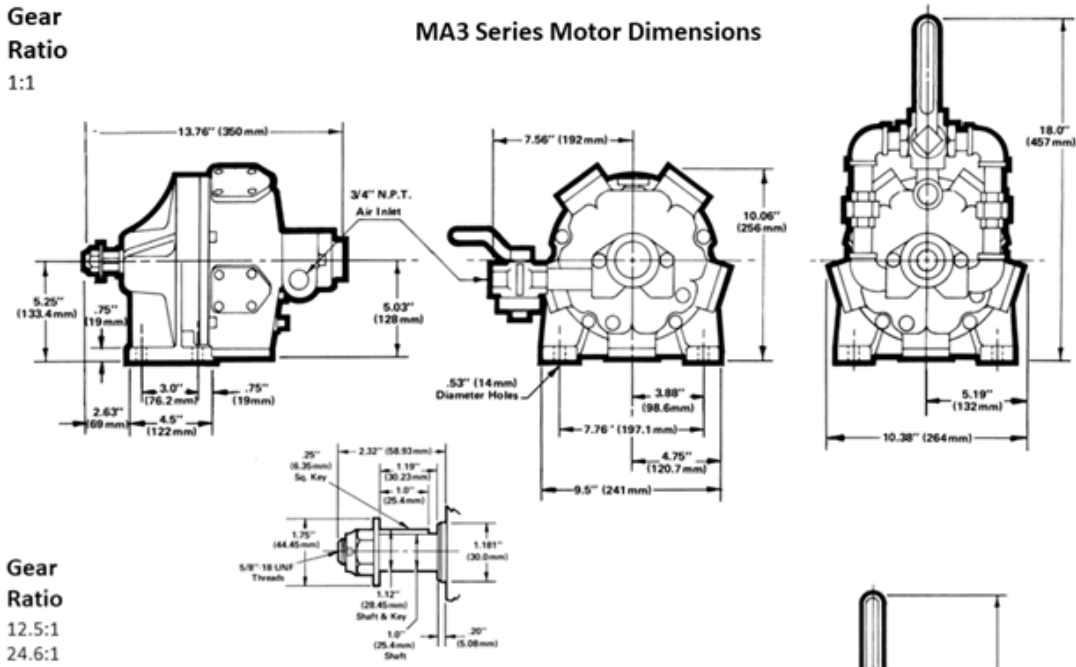

Gear Ratio
12.5:1
24.6:1

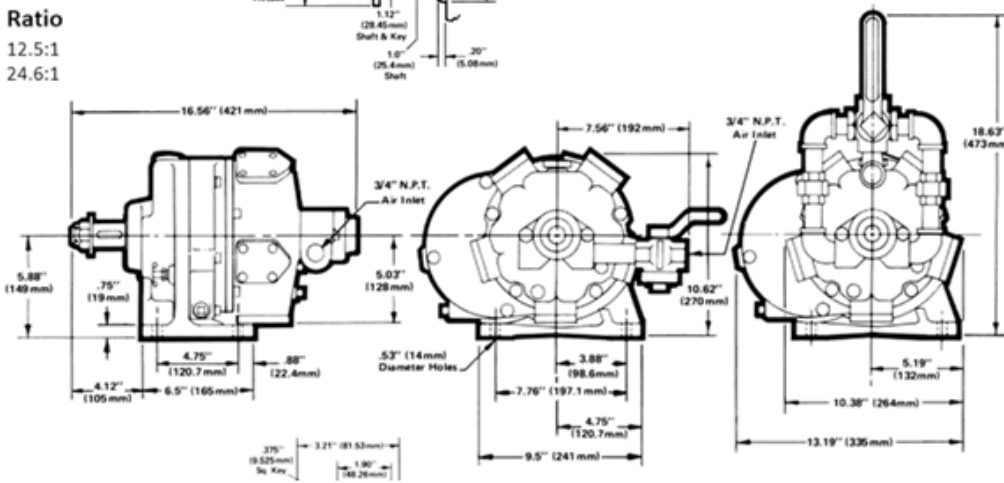

MA3 Power, Torque, Speed

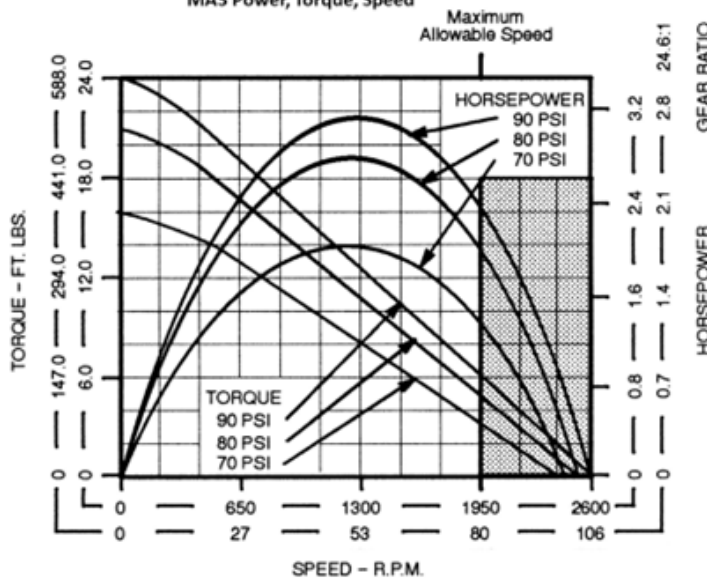

MB Series - Air Motor - Radial Piston

Maximum Power 5.5 hp | 4.10 kw

- Maximum Power 5.5 hp | 4.10 kw
- Torque Range 34 - 700 ft. lbs. | 46 - 949 Nm
- Threaded Spindle

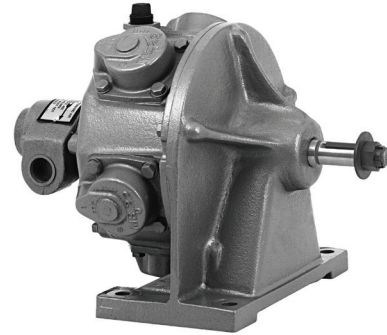

Model	Mount	Spindle Type	RPM at Max HP	Free Speed	Torque Stall	Weight		Gear Ratio	Length	Horsepower	Air Consumption	Control
			r/min	r/min	Ft Lb Nm	Lb	kg		in mm	Hp kW	Scfm	
MBR377M	Foot Mounting	1 1/2in keyed	74	150	700.0 949	148	67.1	20.4-1	18.12 460	5.5	154	Reversible Valving
MBW411M	Foot Mounting	1 1/2in keyed	74	150	700.0 949	148	67.1	20.4-1	18.12 460	5.5	154	No Valving
MBW412M	Foot Mounting	1 1/2in keyed	133	270	388.0 526	148	67.1	11.3-1	18.12 460	5.5	148	No Valving
MBW413M	Foot Mounting	1 1/2in keyed	268	540	192.0 260	148	67.1	5.6-1	18.12 460	5.5	140	No Valving
MBS380M	Foot Mounting	1 1/2in keyed	270	540	192.0 260	145	65.8	5.6-1	18.12 460	5.5	144	Single Direction Valving

All models assume overhung load located at 1" (25.40mm) from face of motor.

These motors must be operated with sufficient load to prevent speed from exceeding maximum allowable speed, 65% of free speed as shown on performance curve.

General:

Air Inlet: 1" NPTF

All tools performance rated @ 90psi (620 kPa) air pressure.

Note: Fill the motor to the proper level before operating. Use engine oil API Service Classified "SC" in the following weights:

Above 32° F: SAE 30W

Below 32° F: SAE 10W

MB Series Motor Dimensions

Gear Ratio

- 5.6-1
- 11.3-1
- 20.4-1

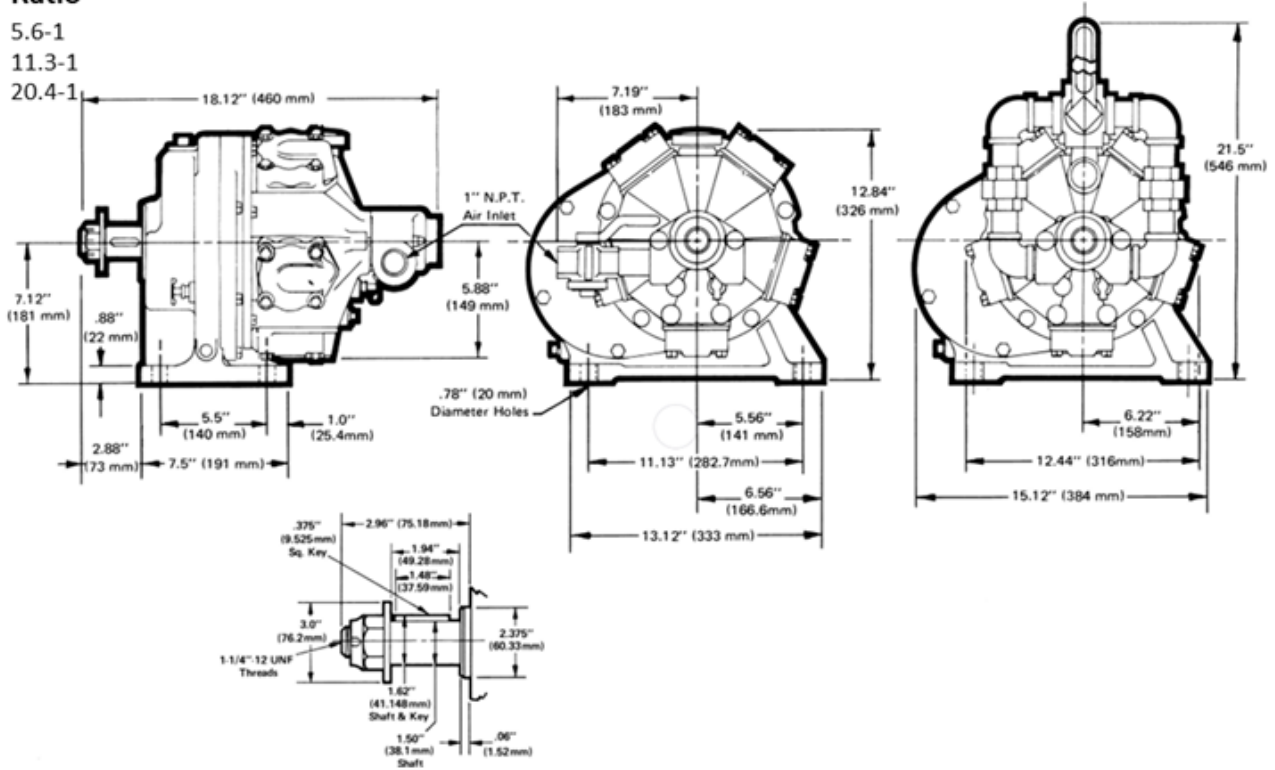

MB Power, Torque, Speed

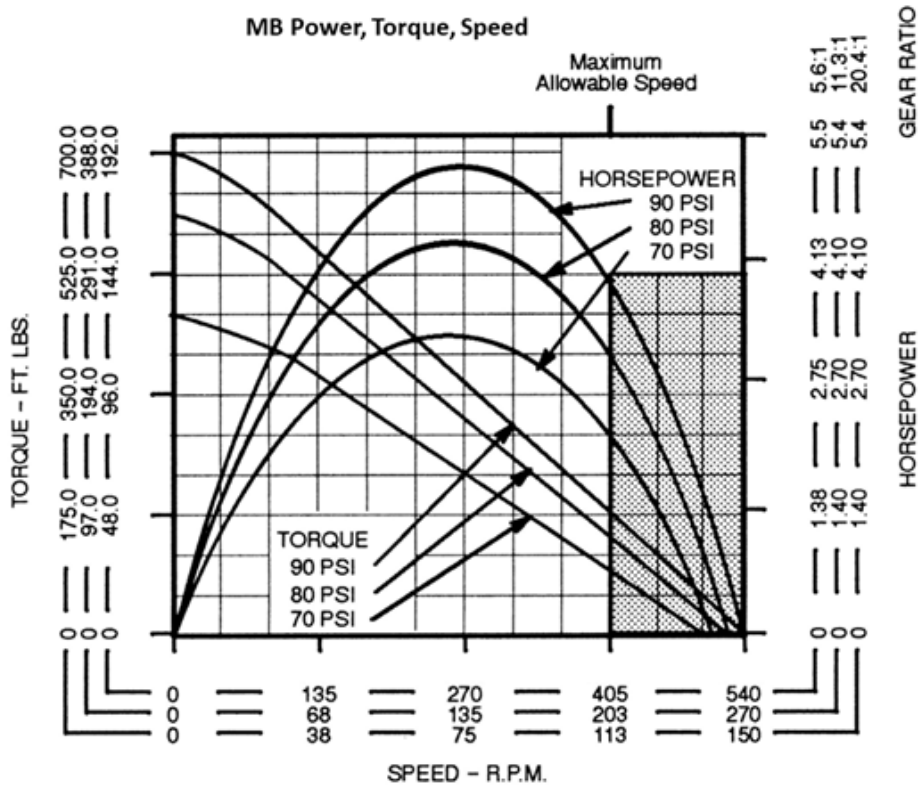

MK Series - Air Motor - Radial Piston

Maximum Power 11 hp | 8.20 kw

- Maximum Power 11 hp | 8.20 kw
- Torque Range 117 - 1654 ft. lbs. | 159 - 2243 Nm
- Threaded Spindle

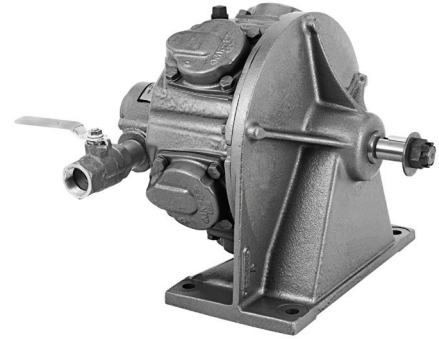

Model	Mount	Spindle Type	RPM at Max HP	Free Speed	Torque Stall	Weight		Gear Ratio	Length	Horsepower	Air Consumption	Control
			r/min	r/min	Ft Lb Nm	Lb	kg		in mm	Hp kW	Scfm	
MKW419M	Foot Mounting	1 1/4 in Threaded Spindle	67	135	1654.0 2243	230	104.3	14.2-1	20.88 530	11	288	No Valving
MKS392M	Foot Mounting	Discontinued	69	135	1654.0 2243	225	102.1	14.2-1	20.88 530	11	293	Single Direction Valving
MKR395M	Foot Mounting	1 1/4 in Threaded Spindle	183	375	606.0 822	230	104.3	5.2-1	20.88 530	11	299	Reversible Valving
MKW420M	Foot Mounting	1 1/4 in Threaded Spindle	183	375	606.0 822	230	104.3	5.2-1	20.88 530	11	299	No Valving
MKW418M	Foot Mounting	1 in Threaded Spindle	975	1900	117.0 159	104	91.6	1-1	20.42 519	11	311	No Valving

All models assume overhung load located at 1" (25.40mm) from face of motor.

These motors must be operated with sufficient load to prevent speed from exceeding maximum allowable speed, 65% of free speed as shown on performance curve.

General:

Air Inlet: 1-1/4" NPTF

All tools performance rated @ 90psi (620 kPa) air pressure.

Note:

Fill the motor to the proper level before operating. Use engine oil API Service Classified "SC" in the following weights:

Above 32° F: SAE 30W

Below 32° F: SAE 10W

Gear Ratio
1:1

MK Series Motor Dimensions

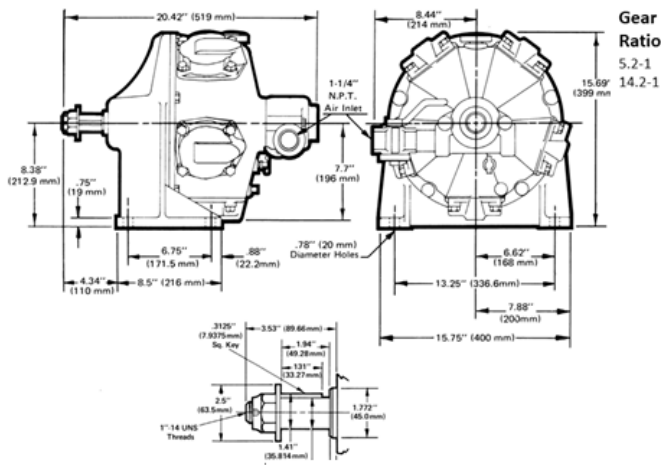

Gear Ratio
5.2-1
14.2-1

MK Series Motor Dimensions

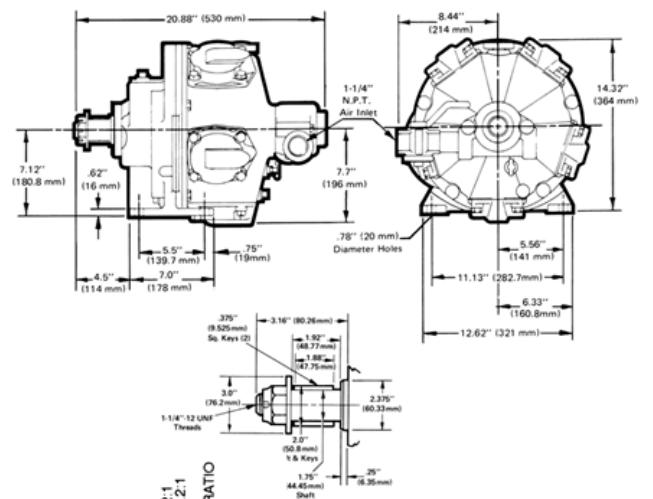

MK Power, Torque, Speed

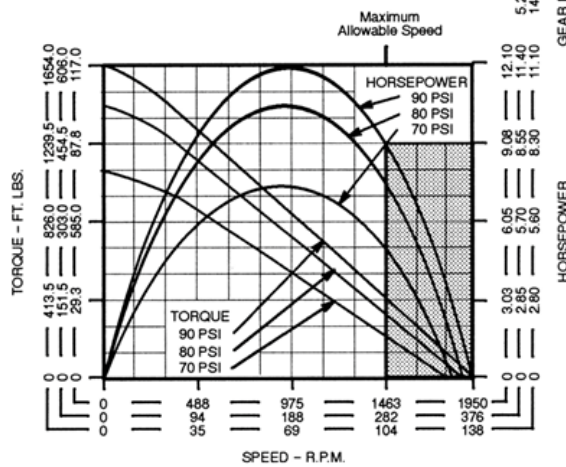

GEAR RATIO
5.2:1
14.2:1

HORSEPOWER

MM Series - Air Motor - Radial Piston

Maximum Power 15 hp | 11.19 kw

- Maximum Power 15 hp | 11.19 kw
- Torque Range 138 - 1952 ft. lbs. | 187 - 2647 Nm
- Threaded Spindle

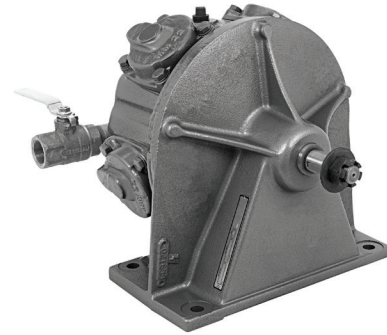

Model	Mount	Spindle Type	RPM at Max HP	Free Speed	Torque Stall	Weight		Gear Ratio	Length	Horsepower	Air Consumption	Control
			r/min	r/min	Ft Lb Nm	Lb	kg		in mm	Hp kW	Scfm	
MMW422M	Foot Mounting	1 1/4 in Threaded Spindle	71	150	1952.0 2647	231	104.8	14.2-1	20.88 530	15	345	No Valving
MMW423M	Foot Mounting	1 1/4 in Threaded Spindle	194	400	715.0 970	231	104.8	5.2-1	20.88 530	15	332	No Valving
MMS400M	Foot Mounting	1 1/4 in Threaded Spindle	206	400	715.0 970	226	102.5	5.2-1	20.88 530	15	336	Single Direction Valving
MMW421M	Foot Mounting	1 1/4 in Threaded Spindle	1010	2100	138.0 187	214	97.1	1-1	20.42 519	15	352	No Valving
MMS396M	Foot Mounting	1 1/4 in Threaded Spindle	1070	2100	138.0 187	210	95.3	1-1	20.42 519	15	348	Single Direction Valving

All models assume overhung load located at 1" (25.40mm) from face of motor.

These motors must be operated with sufficient load to prevent speed from exceeding maximum allowable speed, 65% of free speed as shown on performance curve.

General:

Air Inlet: 1-1/4" NPTF

All tools performance rated @ 90psi (620 kPa) air pressure.

Note:

Fill the motor to the proper level before operating. Use engine oil API Service Classified "SC" in the following weights:

Above 32° F: SAE 30W

Below 32° F: SAE 10W

MM Series Motor Dimensions

MM Series Motor Dimensions

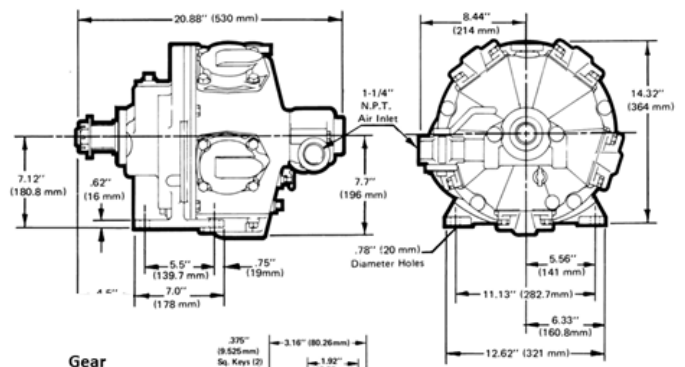
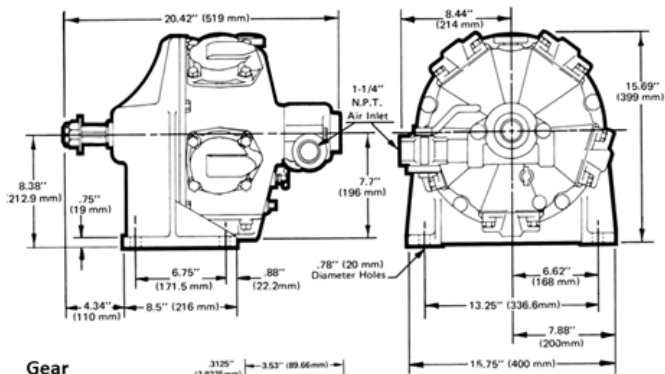

Gear Ratio
1:1

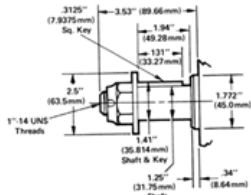

Gear Ratio
5.2-1
14.2-1

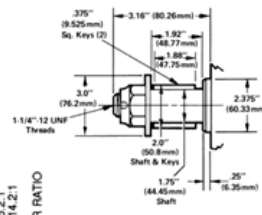

MM Power, Torque, Speed

